

SAMSUNG

VRF

Technical Data Book

DVM S for LA
(R410A, 230V, 60Hz, Heat Pump)



Model : Heat Pump Type (AM***JXVAFH/AZ)

Nomenclature

Outdoor Unit

Model Name

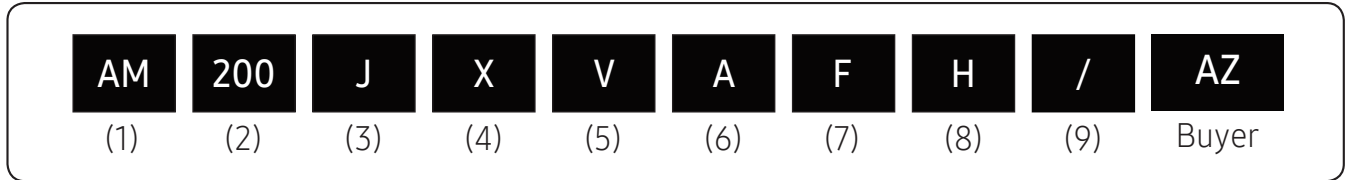

(1) Classification

AM	DVM
-----------	-----

(2) Capacity

x 1/10 HP (3 digits)

(3) Version

F	2013
H	2014
J	2015
K	2016
M	2017

(4) Product Type

X	Outdoor Unit
N	Indoor Unit

(5) Feature 1

V	Inverter
M	DVM S Eco

(6) Feature 2

A	Standard + General Temp.+ Module
H	High EER + Low Temp. + Module
G	High EER + General Temp. + Module
D	Standard + General Temp. + Non-Module

(7) Rating Voltage

C	1Ø, 208~230V, 60Hz
F	3Ø, 208~230V, 60Hz
J	3Ø, 460V, 60Hz

(8) Mode

H	Heat Pump
R	Heat Recovery
C	Cooling Only

(9) Category

A	Anti Corrosion (Corrosion Resistance)
/	Non Anti Corrosion

2. Specification

Standard

Type			DVM S	DVM S	DVM S	DVM S	
Model Name			AM160JXVAFH/AZ	AM180JXVAFH/AZ	AM200JXVAFH/AZ	AM220JXVAFH1AZ	
	Outdoor unit module 1		-	-	-	AM100JXVAFH/AZ	
	Outdoor unit module 2		-	-	-	AM120JXVAFH/AZ	
	Outdoor unit module 3		-	-	-	-	
	Outdoor unit module 4		-	-	-	-	
Power Supply Mode		Ø, #, V, Hz	3, 3, 208-230, 60	3, 3, 208-230, 60	3, 3, 208-230, 60	3, 3, 208-230, 60	
HP			HP	16	18	20	
Performance	Capacity	Cooling	kW	45.0	50.4	56.0	61.6
			Btu/h	153,500	172,000	191,100	210,200
			US RT	12.80	14.33	15.92	17.52
		Heating	kW	50.4	56.7	63.0	69.3
			Btu/h	172,000	193,500	215,000	236,500
			EA	29	32	36	40
Maximum number of connectable indoor units			EA	29	32	36	
Total capacity of the connected Indoor Units			Min.	kW	22.5	25.2	28.0
			Max.	kW	58.5	65.5	72.8
Power	Power Input	Cooling	kW	10.64	10.66	11.45	12.72
		Heating	kW	10.30	10.40	12.70	12.73
	Current Input	Cooling	A	31.00	31.10	33.40	37.10
		Heating	A	30.00	30.30	37.00	37.10
	Current	MCA	A	56.1	66.5	73.0	-
		MFA	A	63	75	80	-
Efficiency	EER	Cooling	W/W	4.23	4.73	4.89	4.84
			Btu/Wh	14.4	16.1	16.7	16.5
	COP	Heating	W/W	4.89	5.45	4.96	5.44
Casing	Material	Body	-	EGI Steel Plate	EGI Steel Plate	EGI Steel Plate	EGI Steel Plate
		Base	-	EGI Steel Plate	EGI Steel Plate	EGI Steel Plate	EGI Steel Plate
Heat Exchanger	Type		-	Fin & Tube	Fin & Tube	Fin & Tube	Fin & Tube
	Material	Fin	-	Al	Al	Al	Al
		Tube	-	Cu	Cu	Cu	Cu
Fin Treatment			-	Anti-corrosion	Anti-corrosion	Anti-corrosion	Anti-corrosion
Compressor	Type		-	Inverter Scroll x 2	Inverter Scroll x 2	Inverter Scroll x 2	Inverter Scroll x 2
	Output		kW x n	5.09 x 2	6.45 x 2	6.45 x 2	(6.45 x 1) x 2
	Model Name		-	DS-GB052FBV* x 2	DS4GJ5066EV* x 2	DS4GJ5066EV* x 2	(DS4GJ5066EV* x 1) x 2
	Oil	Type	-	PVE	PVE	PVE	PVE
Initial charge		cc x n	1,100 x 2	1,100 x 2	1,100 x 2	(1,100 x 1) x 2	
Fan	Type		-	Propeller	Propeller	Propeller	Propeller
	Discharge direction		-	Top	Top	Top	Top
	Quantity		EA	2	2	2	2
	Air Flow Rate		m ³ /min	255	260	265	170 x 1 + 220 x 1
			l/s	4,250	4,333	4,417	2,833 x 1 + 3,667 x 1
	External Static Pressure	Max.	mmAq	8	8	8	8
Pa			78.45	78.45	78.45	78.45	
Fan Motor	Type		-	BLDC Motor	BLDC Motor	BLDC Motor	BLDC Motor
	Output		W x n	620 x 2	620 x 2	620 x 2	(630 x 1) x 2
Piping Connections	Liquid Pipe		Type	Braze connection	Braze connection	Braze connection	Braze connection
			Ø, mm (inch)	12.70 (1/2)	15.88 (5/8)	15.88 (5/8)	15.88 (5/8)
	Gas Pipe		Type	Braze connection	Braze connection	Braze connection	Braze connection
			Ø, mm (inch)	28.58 (1-1/8)	28.58 (1-1/8)	28.58 (1-1/8)	28.58 (1-1/8)
	Heat Insulation			-	Both liquid and gas pipes	Both liquid and gas pipes	Both liquid and gas pipes
	Piping length (ODU-IDU)	Max. [Equiv.]	m	200[220]	200[220]	200[220]	200[220]
	Piping length (1st Branch-IDU)	Max.	m	90	90	90	90
	Total piping length (System)	Max.	m	1,000	1,000	1,000	1,000
	Level difference (ODU in highest position)	Max.	m	110	110	110	110
	Level difference (IDU in highest position)	Max.	m	110	110	110	110
Level difference (IDU-IDU)	Max.	m	50	50	50	50	

2. Specification

Standard

Type			DVMS	DVMS	DVMS	DVMS	
Model Name			AM160JXVAFH/AZ	AM180JXVAFH/AZ	AM200JXVAFH/AZ	AM220JXVAFH1AZ	
	Outdoor unit module 1		-	-	-	AM100JXVAFH/AZ	
	Outdoor unit module 2		-	-	-	AM120JXVAFH/AZ	
	Outdoor unit module 3		-	-	-	-	
	Outdoor unit module 4		-	-	-	-	
Wiring connections	Transmission Cable	Min. Remark	0.75 F1, F2	0.75 F1, F2	0.75 F1, F2	0.75 F1, F2	
	Power supply intake		-	Both indoor and outdoor unit	Both indoor and outdoor unit	Both indoor and outdoor unit	
Refrigerant	Type		-	R410A	R410A	R410A	
	Factory Charging		-	7.7	8.4	8.4	
Sound	Sound Pressure	Cooling	63	64	65	63	
		Heating	65	66	67	66	
	Sound Power		dB(A)	83	86	87	83
External Dimension	Net Weight		kg	290.0	298.0	298.0	
	Shipping Weight		kg	298.0	317.0	317.0	
	Net Dimensions (WxHxD)		mm	1,295 x 1,695 x 765	1,295 x 1,695 x 765	1,295 x 1,695 x 765	(880 x 1,695 x 765) x 2
	Shipping Dimensions (WxHxD)		mm	1,363 x 1,887 x 832	1,363 x 1,887 x 832	1,363 x 1,887 x 832	(948 x 1,887 x 832) x 2
Operating Temp. Range	Cooling		°C	-5 ~ 48	-5 ~ 48	-5 ~ 48	
	Heating		°C	-25 ~ 24	-25 ~ 24	-25 ~ 24	

NOTE

- Specification may be subject to change without prior notice.
 - 1) Performances are based on the following test conditions.
 - Cooling : Indoor temperature 27°CDB, 19°CWB, Outdoor temperature 35°CDB, 24°CWB
 - Heating : Indoor temperature 20°CDB, 15°CWB, Outdoor temperature 7°CDB, 6°CWB
 - Equivalent refrigerant pipe length 5m, Level differences 0m
 - 2) Performance of Multiple Module Outdoor unit is weighted average of Single Module outdoor units.
 - 3) Allowed combination ratio of the total rated indoor unit capacity over the rated outdoor unit capacity is 50~130%.
 - 4) Sound pressure level is obtained in an anechoic room.
 - Sound pressure level is a relative value, depending on the distance and acoustic environment.
 - Sound pressure level may differ depending on operation condition.
 - dBA = A-weighted sound pressure level
 - Reference acoustic pressure 0 dB = 20uPa
 - 5) Sound power level is an absolute value that a sound source generates.
 - dBA = A-weighted sound power level
 - Reference power : 1pW
 - Measured according to ISO 3741
 - 6) Sound values of multi combination are theoretical values based on sound results of individual installed units.
 - 7) These products contain R410A which is fluorinated greenhouse gas.
 - 8) If outdoor unit is located in a higher position than indoor unit, level difference is 110m or under.
(If the level difference is higher than 50m, make a decision by PDM kit installation Guide software whether the PDM kit should be installed or not.)
 - PDM kit: Pressure Drop Modulation kit
When the outdoor unit is below the indoor unit & the level differences are 40m or more, contact your local dealer for more information.
- In case you want to know more information regarding capacity and correction, please refer to capacity table TDB on pvi.samsung.com site.

3. Electrical Characteristics

Standard

Capacity		Model	Power Supply		Voltage Range		Running Current [A]		Current [A]		ODU Fan Motor	
HP	kW		Hz	Voltage	Min. (-10%)	Max. (+10%)	Cooling	Heating	MCA	MFA	kW	FLA [A]
8	22.4	AM080JXVAFH/AZ	60	208-230	187	253	12.7	12.9	28.0	40	0.63	4
10	28.0	AM100JXVAFH/AZ	60	208-230	187	253	16.0	15.5	34.0	50	0.63	4
12	33.6	AM120JXVAFH/AZ	60	208-230	187	253	21.1	21.6	35.0	50	0.63	4
14	40.0	AM140JXVAFH/AZ	60	208-230	187	253	24.7	26.8	50.0	63	1.24	6
16	45.0	AM160JXVAFH/AZ	60	208-230	187	253	31.0	30.0	56.1	63	1.24	6
18	50.4	AM180JXVAFH/AZ	60	208-230	187	253	31.1	30.3	66.5	75	1.24	6
20	56.0	AM200JXVAFH/AZ	60	208-230	187	253	33.4	37.0	73.0	80	1.24	6
22	61.6	AM220JXVAFH1AZ	60	208-230	187	253	37.1	37.1	-	-	-	-
24	67.2	AM240JXVAFH1AZ	60	208-230	187	253	42.2	43.2	-	-	-	-
26	72.8	AM260JXVAFH1AZ	60	208-230	187	253	45.8	48.4	-	-	-	-
28	78.6	AM280JXVAFH1AZ	60	208-230	187	253	52.1	51.6	-	-	-	-
30	84.0	AM300JXVAFH1AZ	60	208-230	187	253	52.2	51.9	-	-	-	-
32	89.6	AM320JXVAFH1AZ	60	208-230	187	253	54.5	58.6	-	-	-	-
34	96.0	AM340JXVAFH1AZ	60	208-230	187	253	58.1	63.8	-	-	-	-
36	101.0	AM360JXVAFH1AZ	60	208-230	187	253	64.4	67.0	-	-	-	-
38	106.4	AM380JXVAFH1AZ	60	208-230	187	253	64.5	67.3	-	-	-	-
40	112.8	AM400JXVAFH1AZ	60	208-230	187	253	66.8	74.0	-	-	-	-
42	117.8	AM420JXVAFH1AZ	60	208-230	187	253	70.5	74.1	-	-	-	-
44	123.2	AM440JXVAFH1AZ	60	208-230	187	253	75.6	80.2	-	-	-	-
46	128.8	AM460JXVAFH1AZ	60	208-230	187	253	79.2	85.4	-	-	-	-
48	134.4	AM480JXVAFH1AZ	60	208-230	187	253	85.5	88.6	-	-	-	-
50	140.0	AM500JXVAFH1AZ	60	208-230	187	253	85.6	88.9	-	-	-	-
52	145.6	AM520JXVAFH1AZ	60	208-230	187	253	87.9	95.6	-	-	-	-
54	151.4	AM540JXVAFH1AZ	60	208-230	187	253	91.5	100.8	-	-	-	-
56	156.8	AM560JXVAFH1AZ	60	208-230	187	253	97.8	104.0	-	-	-	-
58	162.4	AM580JXVAFH1AZ	60	208-230	187	253	97.9	104.3	-	-	-	-
60	168.0	AM600JXVAFH1AZ	60	208-230	187	253	100.2	111.0	-	-	-	-
62	173.6	AM620JXVAFH1AZ	60	208-230	187	253	103.9	111.1	-	-	-	-
64	179.2	AM640JXVAFH1AZ	60	208-230	187	253	109.0	117.2	-	-	-	-
66	185.6	AM660JXVAFH1AZ	60	208-230	187	253	112.6	122.4	-	-	-	-
68	190.6	AM680JXVAFH1AZ	60	208-230	187	253	118.9	125.6	-	-	-	-
70	196.0	AM700JXVAFH1AZ	60	208-230	187	253	119.0	125.9	-	-	-	-
72	201.6	AM720JXVAFH1AZ	60	208-230	187	253	121.3	132.6	-	-	-	-
74	207.2	AM740JXVAFH1AZ	60	208-230	187	253	124.9	137.8	-	-	-	-
76	212.8	AM760JXVAFH1AZ	60	208-230	187	253	131.2	141.0	-	-	-	-
78	218.4	AM780JXVAFH1AZ	60	208-230	187	253	131.3	141.3	-	-	-	-
80	224.0	AM800JXVAFH1AZ	60	208-230	187	253	133.6	148.0	-	-	-	-

 **NOTE**

- MCA : Minimum circuit amperes
- MFA : Maximum fuse amperes
- FLA : Full load amperes

4. Dimensional Drawing

Outdoor unit

- AM140~200JXVAFH/AZ

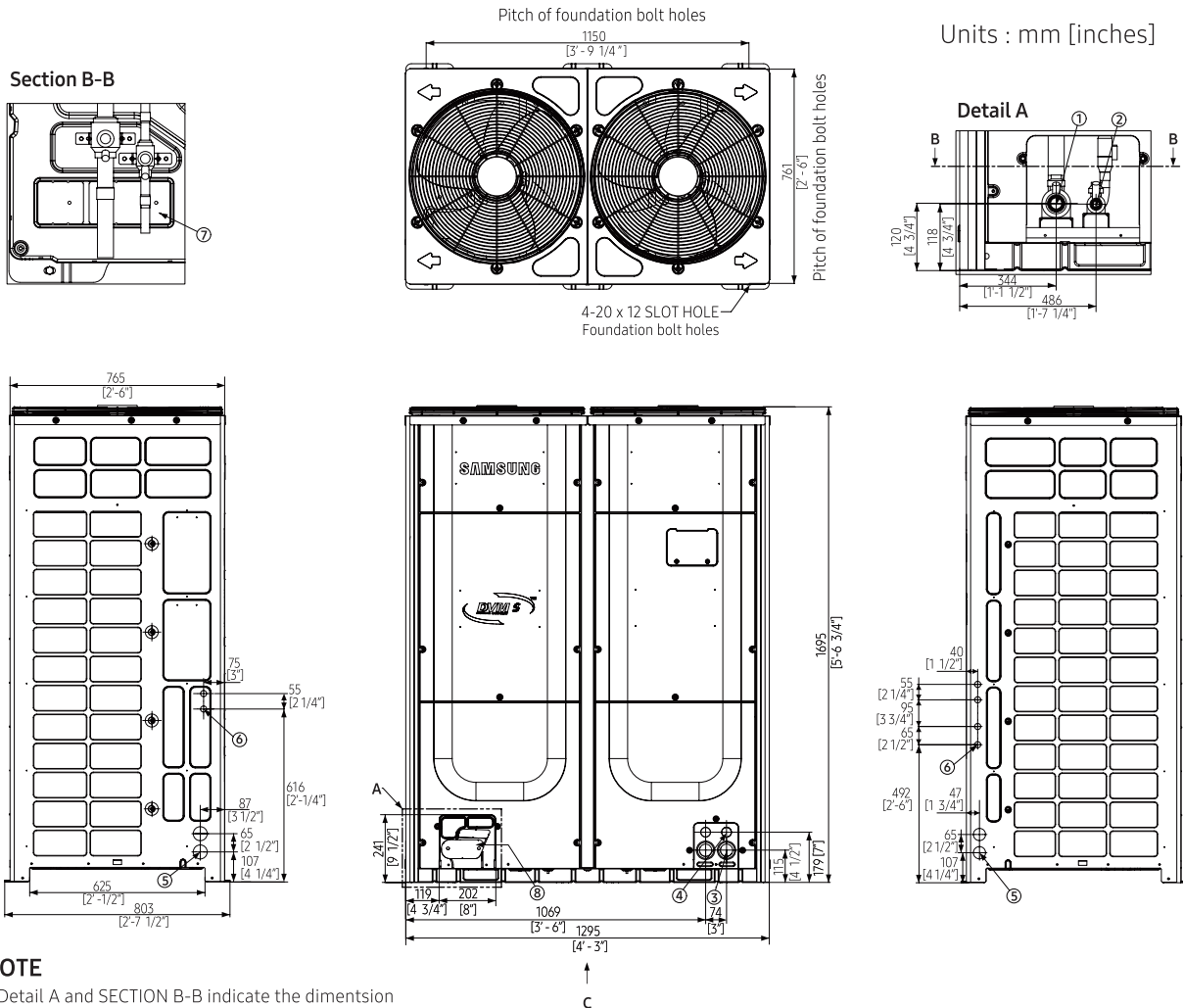

NOTE

- Detail A and SECTION B-B indicate the dimension after fixing the attached piping.
- Item 3-8 : Knock-out hole.
- View C indicate the dimension of knock-out hole(bottom)
- Pipe [Φ, mm(inch)] : Brazing connection

HP	Liquid pipe	Gas pipe
8	9.52(3/8)	19.05(3/4)
10	9.52(3/8)	22.22(7/8)
12	12.70(1/2)	28.58(1 1/8)
14	12.70(1/2)	28.58(1 1/8)
16	12.70(1/2)	28.58(1 1/8)
18	15.88(5/8)	28.58(1 1/8)
20	15.88(5/8)	28.58(1 1/8)
22	15.88(5/8)	28.58(1 1/8)
24	15.88(5/8)	34.92(1 3/8)
26	19.05(3/4)	34.92(1 3/8)
28	19.05(3/4)	34.92(1 3/8)
30	19.05(3/4)	34.92(1 3/8)

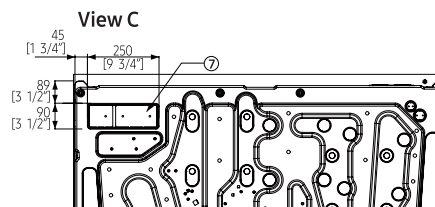

NO	Table of descriptions	Remark	NO	Table of descriptions	Remark
1	Gas Ref. pipe	See note 4.	5	Power wiring conduit	Φ44
2	Liquid Ref. pipe	See note 4.	6	Communication wiring conduit	Φ22
3	Power wiring conduit	Φ44	7	Knock-out Hole for Ref. Piping (bottom)	
4	Communication wiring conduit	Φ34	8	Knock-out Hole for Ref. Piping (front)	

6. Electrical Wiring Diagrams

Outdoor unit

- AM080JXVAFH/AZ, AM140JXVAFH/AZ, AM160JXVAFH/AZ

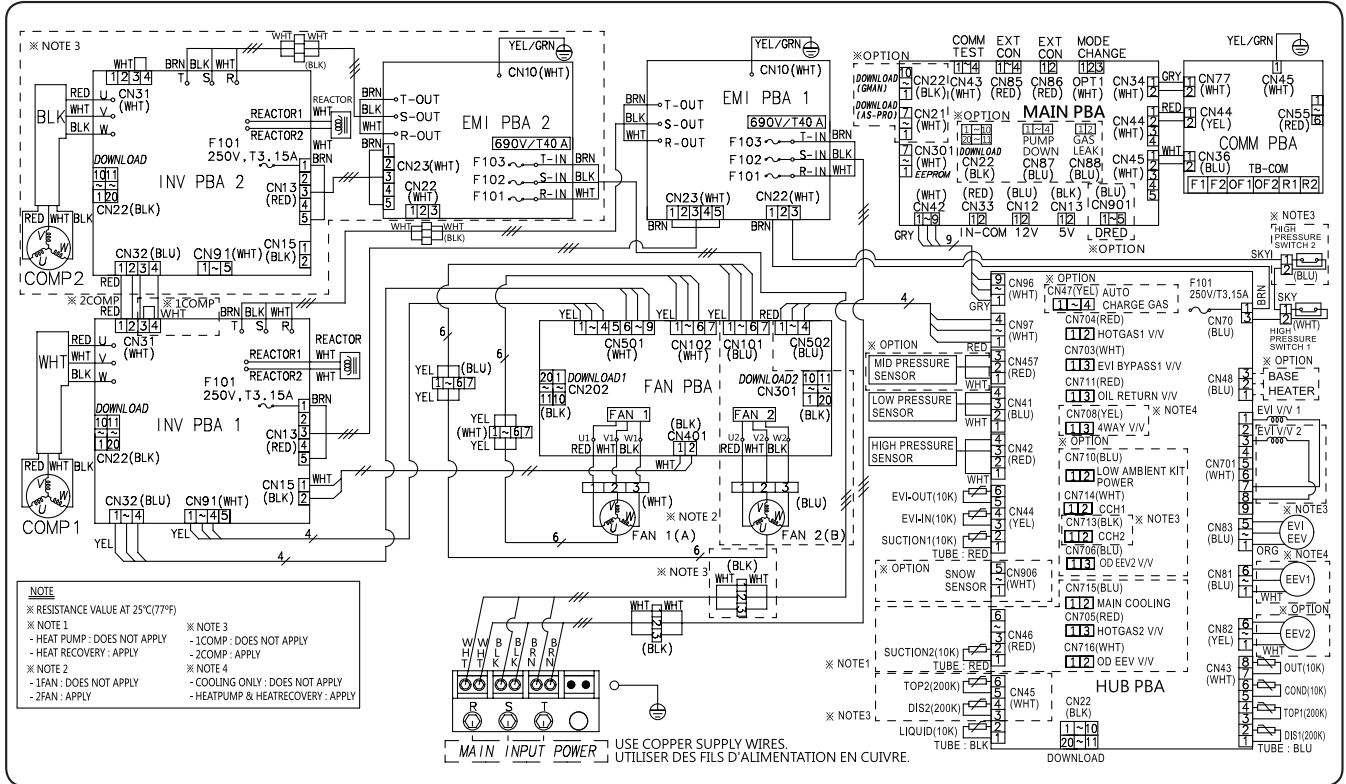

INV PBA1	Printed circuit board (inverter1)	EEV1	Electronic expansion valve 1	LIQUID(10K)	Thermistor LIQUID(10K)
INV PBA2	Printed circuit board (inverter2)	EEV2	Electronic expansion valve 2	HOTGAS1 V/V	Solenoid valve(HOTGAS1)
EMI PBA1	Printed circuit board (emi1)	EVI-OUT(10K)	Thermistor(Enhanced Vapor Injection out)	EVI BYPASS V/V	Solenoid valve(EVI BYPASS)
EMI PBA2	Printed circuit board (emi2)	EVI-IN(10K)	Thermistor (Enhanced Vapor Injection_in)	RETURN V/V	Solenoid valve(RETURN)
FAN PBA	Printed circuit board (fan motor)	SUCTION1(10K)	Thermistor (SUCTION1)	4WAY V/V	Solenoid valve(4WAY)
MAIN PBA	Printed circuit board (main)	SUCTION2(10K)	Thermistor (SUCTION2)	CCH1	Crank Case Heater (Compressor1)
HUB PBA	Printed circuit board (hub)	SNOW SENSOR	SNOW SENSOR	CCH2	Crank Case Heater (Compressor2)
COMM PBA	Printed circuit board (communication)	OIL-COMP1	Oil-Sensor(Compressor1)	MAIN COOLING	Solenoid valve(Main cooling)
COMP1	Motor (compressor1)	OIL-COMP2	Oil-Sensor (Compressor2)	HOTGAS2 V/V	Solenoid valve(HOTGAS2)
COMP2	Motor (compressor2)	OUT(10K)	Thermistor (Air)	OD EEV V/V	Solenoid valve(OD EEV)
FAN1	Motor (fan1)	COND(10K)	Thermistor (COND.)	F101	FUSE(inverterPBA)
FAN2	Motor (fan2)	TOP2(200K)	Thermistor (Copressor2 TOP)	690V/T40A	FUSE(EMI PBA)
EVI V/V1	Solenoid valve (Enhanced Vapor Injection_1)	DIS1(200K)	Thermistor DIS1(200K)	MODE CHANGE	Connector (remote switching cool/heat selector)
EVI V/V2	Solenoid valve (Enhanced Vapor Injection_2)	DIS2(200K)	Thermistor DIS2(200K)	EXT CON	Connector (Output EXT CON)
EVI EEV	Electronic expansion valve (EVI)	LIQUID(10K)	Thermistor LIQUID(10K)	ERROR/COMPEXT	Connector (Output ERROR/COMP EXT CON)

NOTE

- This wiring diagram applies only to the outdoor unit.
- Colors blk: black, red: red, blu: blue, wht: white, yel: yellow, brn: brown, sky: skyblue
- When operating, don't shortcircuit the protection device (High Pressure switch)
- For connection wiring indoor-outdoor transmission OF1-OF2, outdoor_outdoor transmission OF1-OF2, refer to the installation manual.
- ⊕ Protective earth(screw), □ : connector, $\frac{N}{\text{---}}$: The wire quantity

7. Sound Data

Summary

Standard

Capacity		Model	Sound Pressure dB(A)		Sound Power dB(A)
HP	kW		Cooling	Heating	
8	22.4	AM080JXVAFH/AZ	57	59	77
10	28.0	AM100JXVAFH/AZ	58	62	79
12	33.6	AM120JXVAFH/AZ	62	64	81
14	40.0	AM140JXVAFH/AZ	61	63	81
16	45.0	AM160JXVAFH/AZ	63	65	83
18	50.4	AM180JXVAFH/AZ	64	66	86
20	56.0	AM200JXVAFH/AZ	65	67	87
22	61.6	AM220JXVAFH1AZ	63	66	83
24	67.2	AM240JXVAFH1AZ	65	67	84
26	72.8	AM260JXVAFH1AZ	65	67	84
28	78.6	AM280JXVAFH1AZ	66	68	85
30	84.0	AM300JXVAFH1AZ	66	68	87
32	89.6	AM320JXVAFH1AZ	67	69	88
34	96.0	AM340JXVAFH1AZ	66	68	88
36	101.0	AM360JXVAFH1AZ	67	69	88
38	106.4	AM380JXVAFH1AZ	68	70	90
40	112.8	AM400JXVAFH1AZ	68	70	90
42	117.8	AM420JXVAFH1AZ	67	70	88
44	123.2	AM440JXVAFH1AZ	68	70	89
46	128.8	AM460JXVAFH1AZ	68	70	89
48	134.4	AM480JXVAFH1AZ	68	70	89
50	140.0	AM500JXVAFH1AZ	69	71	90
52	145.6	AM520JXVAFH1AZ	69	71	91
54	151.4	AM540JXVAFH1AZ	69	71	91
56	156.8	AM560JXVAFH1AZ	69	71	91
58	162.4	AM580JXVAFH1AZ	69	71	91
60	168.0	AM600JXVAFH1AZ	70	72	92
62	173.6	AM620JXVAFH1AZ	69	71	91
64	179.2	AM640JXVAFH1AZ	70	72	91
66	185.6	AM660JXVAFH1AZ	70	72	91
68	190.6	AM680JXVAFH1AZ	70	72	91
70	196.0	AM700JXVAFH1AZ	70	72	92
72	201.6	AM720JXVAFH1AZ	70	72	92
74	207.2	AM740JXVAFH1AZ	70	72	92
76	212.8	AM760JXVAFH1AZ	71	73	92
78	218.4	AM780JXVAFH1AZ	71	73	93
80	224.0	AM800JXVAFH1AZ	71	73	93

NOTE

- Sound Pressure Level
 - Sound pressure level is obtained in an anechoic room.
 - Sound pressure level is a relative value, depending on the distance and acoustic environment.
 - Sound pressure level may differ depending on operation condition.
 - dBA = A-weighted sound pressure level
 - Reference acoustic pressure 0 dB = 20μPa
- Sound Power Level
 - Sound power level is an absolute value that a sound source generates.
 - dBA = A-weighted sound power level.
 - Reference power : 1pW.
 - Measured according to ISO 3741.

9. Piping Diagram

Outdoor unit

(2) AM140~200JXVAFH/AZ

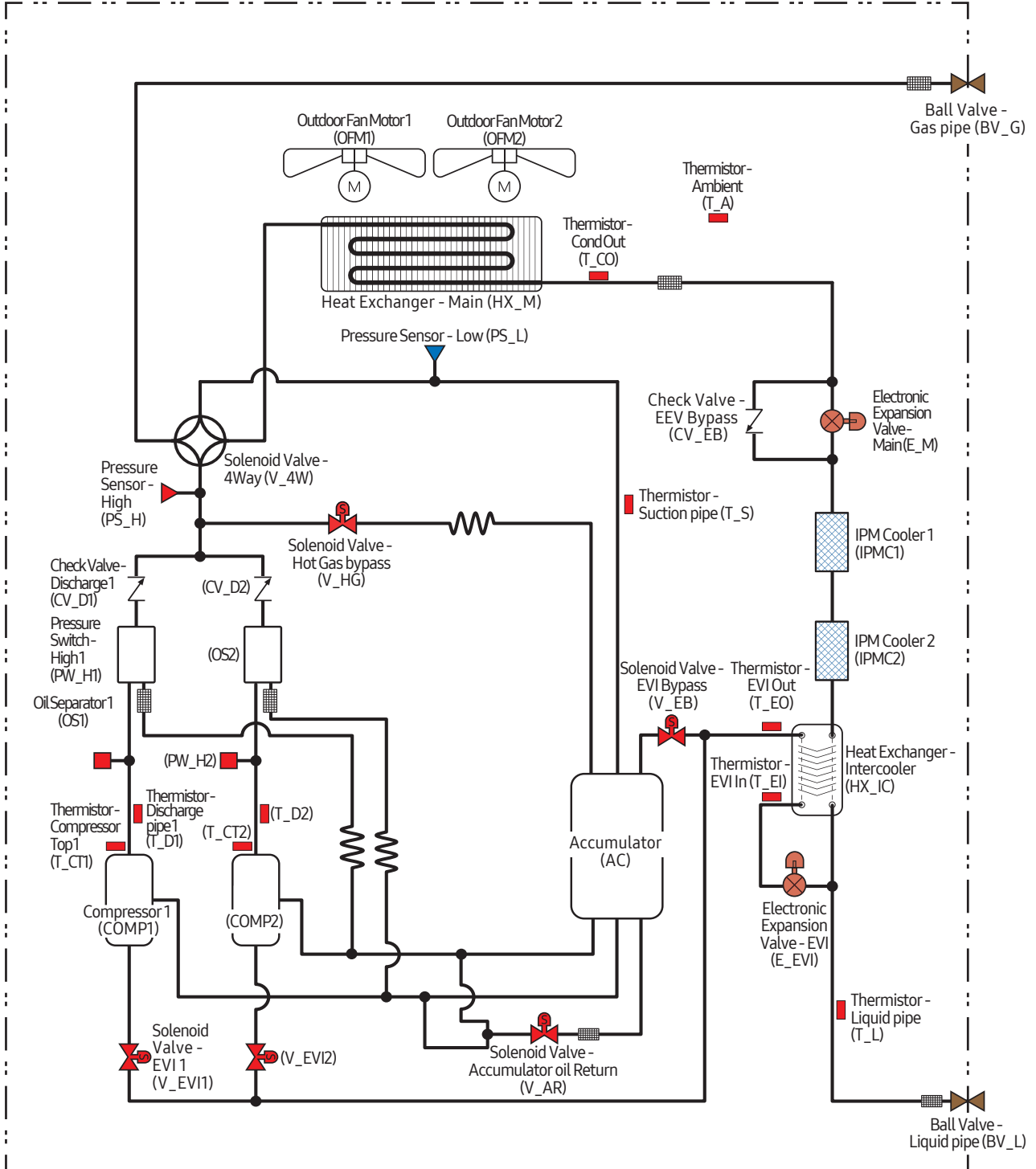

2019.05
Ver.2.0